

Service Information Letter

SIL 4305-150-01

Remote Directional Gyro

4305-150 ONLY

Rotor Speed Test Point

1. PLANNING INFORMATION

This service information is applicable to the 4305-150 Remote Directional Gyro manufactured by the General Design Division of Mid-Continent Instrument Co., Inc. This service may be required if the rotor speed output on pin 9 of external connector J1 is used for unit testing at an appropriately rated repair facility.

NOTE: This output is NOT used in any current aircraft installations.

During maintenance of the unit the output on J1-9 could be used as a test point for unit operational performance. On units manufactured prior to March 2002 this rotor speed test point may provide unstable readings. To correct this unstable reading a 22Kohm resistor should be added from pin 2 of Op Amp U8A to ground. Refer to the following drawings.

All units manufactured beginning April 1, 2002 will contain this change.

Resistor P/N = 51-2202-52C, 22Kohm, 5%, 1/4W (R36 on the drawing).

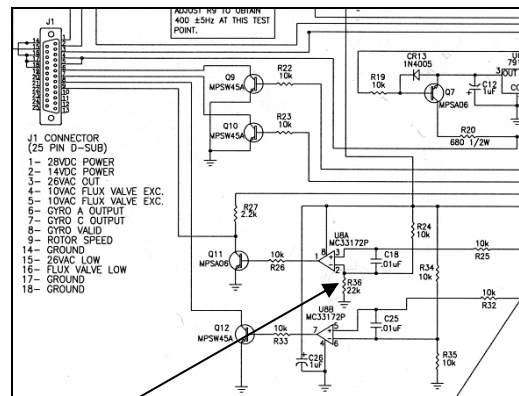
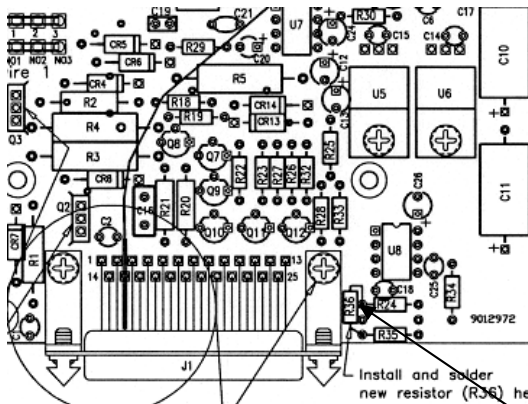

R36 ADDED